

# Cost Minimization Planning for Greenfield Passive Optical Networks

Ji Li and Gangxiang Shen

**Abstract**—We plan greenfield PON networks to minimize their total deployment costs. We propose an efficient heuristic called the Recursive Association and Relocation Algorithm (RARA) to solve the optimization problem. Our algorithm can significantly reduce PON network deployment costs compared to an intuitive random-cut sectoring approach. To further tune down the costs, we also exploit the opportunity of cable conduit sharing by proposing an extension to RARA. Our case studies show that there are saturating trends for the PON deployment costs with the increase of the three system parameters, including maximal optical split ratio, maximal transmission distance, and maximal differential distance. Also, to reduce computation time for large PON deployment scenarios, we propose a disintegration planning method to divide a large planning scenario into several small ones. The method is found to be effective to provide close performance, but require much less computation, compared to the situation without disintegration.

**Index Terms**—PON deployment; Cost minimization; Sectoring approach; RARA; Disintegration.

## I. INTRODUCTION

With the growing popularity of bandwidth-intensive services such as HDTV, VoD, peer-to-peer, and video conferencing applications, there is an increasing demand on broadband access. To meet this demand, the access networks are evolving from the traditional DSL and cable techniques to a new generation of fiber-based access techniques. Fibers are permeating from the curb (FTTC), through the building

(FTTB) and the node (FTTN), eventually to the home (FTTH) [2,3]. Today there are two major types of passive optical access networks (PONs), i.e., Ethernet passive optical networks (EPONs) [2,4] and gigabit-capable passive optical networks (GPONs) [5,6]. EPON is a type of network based on the traditional Ethernet technique. An EPON can provide 1 Gb/s capacity in both upstream and downstream directions and cover a distance of up to 20 km as well as support a 20 km differential distance.<sup>1</sup> In contrast, GPON is a standard evolved from the traditional ATM PON (APON) technique. A GPON can support higher bandwidth, up to 2.5 Gb/s, in both upstream and downstream directions. It can cover a longer distance, up to 60 km, and support a differential distance of up to 20 km.

Much research has been carried out for passive optical networks. First, as bandwidth allocation in the upstream direction in both EPON and GPON is one of the most challenging issues, many investigations have been dedicated to efficient bandwidth allocation and QoS support [2,7,8]. A range of efficient scheduling and bandwidth allocation strategies have been developed and evaluated [7,8]. Second, transmission distance and capacity are also essential to passive optical networks. In order to support users in rural areas who are far away from a central office, the maximal transmission distance of a PON is being extended from standardized 20 km or 60 km, to up to 100 km [9]. Also, to provide even higher bandwidth, a new generation of PON techniques is being developed to increase the transmission capacity by either shortening the time duration of each data bit or increasing the number of parallel transmission channels. IEEE 10G EPON standards are being developed to increase the EPON transmission capacity from 1 Gb/s to 10 Gb/s [10]. Wavelength division multiplexing (WDM) transmission techniques are also being applied to upgrade PON transmission capacity several times [9].

On the other hand, optimal design and planning for PON networks is important to PON deployment.

<sup>1</sup>We define the *coverage* (also called *reach*) of a PON as the maximal transmission distance between an OLT and an ONU and the *differential distance* for a PON as the difference between the fiber distances of different ONUs to a central OLT within the PON.

Manuscript received March 10, 2008; revised April 26, 2009; accepted May 4, 2009; published June 1, 2009 (Doc. ID 111138).

Part of this research has been presented at OFC/NFOEC 2008 [1].

Ji Li is with the Australian Research Council Special Research Centre for Ultra-Broadband Information Networks (CUBIN), an affiliated program of National ICT Australia, Electrical and Electronic Engineering (EEE) Department, The University of Melbourne, Victoria 3010, Australia (e-mail: jili@ee.unimelb.edu.au).

G. Shen was with the University of Melbourne. Now he is with Ciena Corporation, 920 Elkridge Landing Road, Linthicum, Maryland 21090, USA (e-mail: egxshen@gmail.com).

Digital Object Identifier 10.1364/JOCN.1.000017

Little research has been performed in this direction. Only very recently, there was a study that tried to minimize the total PON network deployment cost [11]. The study, however, considered several small deployment scenarios. More generalized approaches are thus required for practical deployment with hundreds of optical network units (ONUs).

In this paper, we consider a generic approach for *greenfield*<sup>2</sup> PON network deployment, which is capable of planning a large network scenario with hundreds of ONUs. We formulate the research problem of PON network design and planning. We also develop mathematical optimization models for the problem. Due to high computational complexity of solving the optimization model, we also propose an efficient heuristic called the Recursive Association and Relocation Algorithm (RARA) for suboptimal solutions. Extensive simulation studies indicate that the proposed approach RARA is much more efficient than an intuitive random-cut sectoring approach. In addition, we evaluate the impacts of PON system constraints, such as optical split ratio, maximal PON transmission distance, and maximal PON differential distance, on the overall cost of PON deployment.

The rest of the paper is structured as follows. In Section II, we elaborate on the PON network deployment problem and develop a mathematical optimization model for the problem. In Section III, we introduce an intuitive random-cut sectoring approach and an efficient heuristic, called the Recursive Association and Relocation Algorithm (RARA). We also improve the performance of RARA by combining it with an extended minimum spanning tree (MST) approach to exploit the benefit of cable conduit sharing among multiple fiber links. In Section IV, we conduct simulations to evaluate the performance of the proposed approaches and gain insights into the factors that affect costs of PON deployment. We conclude the paper in Section VI.

## II. PROBLEM DEFINITION AND MATHEMATICAL OPTIMIZATION MODEL

### A. Problem Definition

Figure 1 shows an example of PON network planning and deployment. Given a set of disperse locations, with one ONU at each location, and a central office on a given position, from which passive optical networks are deployed to connect to the ONUs, our objective for PON network deployment is to minimize its total cost. Specifically, the total cost is composed of various subcosts, including (i) the system cost of PON, such as the costs of optical line terminals (OLTs) and

<sup>2</sup>Here the “greenfield” that we are considering is a kind of situation where central offices have been constructed, while fiber conduits and splitter cabinets are to be planned.

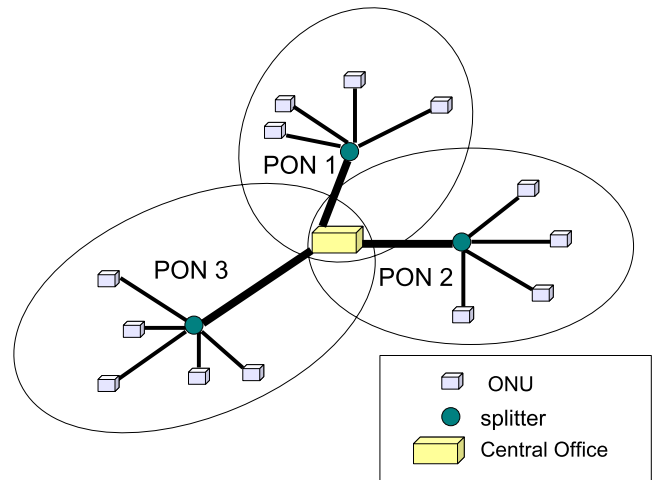

Fig. 1. (Color online) Illustration of PON networks.

optical splitters, (ii) the labor cost for trenching and laying fibers, and (iii) the cost of fiber cables.

In general, among all the above costs, the labor cost of trenching and laying fibers is the most expensive, which overwhelms all the other costs in the whole deployment. In addition, for PONs with different reaches, the costs of their OLTs are different. A long-reach PON generally has a more expensive OLT than a short-reach PON. Also, for trenching and laying fibers, in addition to the labor cost there could be other costs such as the costs for a trenching permit, traffic interruption, and other city considerations. However, for simplicity in this study we have ignored the cost difference of OLTs and also do not consider the extra costs like a trenching permit because without real data these costs are always uncertain.

The optimization problem needs to consider several PON system constraints, including (i) maximal transmission distance, (ii) maximal differential distance, and (iii) optical split ratio. Typically, the optical split ratio ranges from 1:4, 1:8, 1:16, 1:32, 1:64, to up to 1:128. A 1: $n$  optical splitter means that up to  $n$  ONUs can be connected to the splitter.<sup>3</sup>

In addition to the above system constraints, there could be other constraints, such as legacy routing/conduits, road maps, private properties, and so on. This study assumes a greenfield deployment, in which central offices have been constructed and fiber conduits and splitter cabinets are to be planned. The assumptions are practical for the PON deployment in some rural areas and developing countries, where all the network facilities need to be built from zero. For more complicated constraints such as legacy routing/conduits and road maps, the current greenfield net-

<sup>3</sup>Given a specific optical split ratio, each user is ensured with a certain average data rate. For example, in a 1:16 EPON each ONU can obtain an average 60 Mb/s data rate. Thus, by controlling the maximal split ratio, we can control the bandwidth provided to each ONU user.

work is still useful. First, the solutions to the current greenfield design can serve as lower bounds on the designs that consider more constraints. Second, the approach developed in the paper can function as a baseline for extensions when more specific constraints are considered. For example, if a fiber link of an optimization solution based on the greenfield planing needs to cross a private property, which is, however, not accessible, we may make a local bypass to get around the property.

### B. Mathematical Optimization Model

We develop an optimization model for the problem, which is as follows:

• **Sets:**

- **S**: set of splitters. The size of **S** is the maximal number of splitters allowed for a deployment. We normally set a large size as a starting point though the actual required number of splitters is smaller in the final solution. For example, if there are 500 ONUs in a design, then we can set the splitter set size to be 500 since each ONU can only connect to a single splitter.
- **T<sub>s</sub>**: set of splitter types, which is based on the split ratios. The splitter types can range from 1:4, 1:8, 1:16, 1:32, 1:64, to up to 1:128 according to the PON standards.
- **U**: set of ONUs. Each ONU corresponds to a geographic position in a Euclidean plane.

• **Parameters:**

- $x_0, y_0$ : the position coordinates of the central office (CO).
- $x_i^o, y_i^o$ : the position coordinates of the  $i$ th ONU,  $i \in \mathbf{U}$ .
- $\Delta$ : a large value, which is set to be  $10^5$  in this study.
- $T_k$ : the total number of outlet ports of the  $k$ th type of splitter. For example, a 1:8 splitter has eight outlet ports.
- $\alpha$ : the cost factor or weight of the OLT. As mentioned, though there can be a cost difference for different types of OLTs under different PON reaches, for simplicity we use a single cost factor for all types of OLTs.
- $\beta_j$ : the cost factor or weight of each outlet port of the  $i$ th type of splitter. For simplicity, we assume that the cost of each outlet port of each type of splitter in set **T<sub>s</sub>** is identical.
- $\gamma$ : the cost factor or weight of trenching and laying fibers (per kilometer). In this study, we assume a uniform cost for trenching and laying fibers though the cost can be increased under some situations at which a trenching permit may be required or other city considerations should be taken into account.

- $\theta$ : the cost factor or weight of fiber cables (per kilometer).
- $l_{\max}^{\text{total}}$ : the maximal transmission distance of a PON between an OLT and an ONU, which is generally less than 100 km.
- $l_{\max}^{\text{diff}}$ : the maximal differential distance between different ONUs within the same PON, which is generally less than 20 km.

• **Variables:**

- $x_i^s, y_i^s$ : the position coordinates of the  $i$ th splitter,  $i \in \mathbf{S}$ .
- $\Phi_i$ : the usage indicator function of the  $i$ th splitter. It takes the value of one if the splitter is used; otherwise, zero.
- $\Psi_i^j$ : the connection or association indicator function between the  $j$ th ONU and the  $i$ th splitter. It takes the value of one if the ONU is connected to the splitter; otherwise, zero.
- $\pi_i^k$ : the splitter type indicator function of the  $i$ th splitter. It takes the value of one if the splitter is the  $k$ th type; otherwise, zero.
- $l_i^s$ : the distance from the  $i$ th splitter to the central OLT.
- $l_i^j$ : the distance from the  $j$ th ONU to the  $i$ th splitter.
- $l_i^{\max}$ : the maximal distance from an ONU to the OLT in the  $i$ th PON,  $i \in \mathbf{S}$ . Each PON corresponds to a splitter.
- $l_i^{\min}$ : the minimal distance from an ONU to the OLT in the  $i$ th PON.
- $\tau_i, \xi_i^j$ : intermediate binary variables for “if and then” conditions in the optimization model.

- The objective is to minimize the total cost of PON deployment that interconnects all the ONUs to the central OLTs, subject to the PON system constraints including maximal transmission distance, maximal differential distance, and optical split ratio.

**Objective:** minimize

$$\alpha \sum_{i \in \mathbf{S}} \Phi_i + \beta \sum_{i \in \mathbf{S}} \sum_{k \in \mathbf{T}_s} \Phi_i T_k \pi_i^k + (\gamma + \theta) \times \left( \sum_{i \in \mathbf{S}} \Phi_i l_i^s + \sum_{i \in \mathbf{S}} \sum_{j \in \mathbf{U}} \Psi_i^j l_i^j \right). \quad (1)$$

• **Constraints:**

$$\sum_{i \in \mathbf{S}} \Psi_i^j = 1, \quad \forall j \in \mathbf{U}; \quad (2)$$

$$\Delta \cdot \Phi_i \geq \sum_{j \in \mathbf{U}} \Psi_i^j, \quad \forall i \in \mathbf{S}; \quad (3)$$

$$\sum_{j \in \mathbf{U}} \Psi_i^j \leq \sum_{k \in \mathbf{T}_s} T_k \cdot \pi_i^k, \quad \forall i \in \mathbf{S}; \quad (4)$$

$$\sum_{k \in \mathbf{T}_s} \pi_i^k - 1 \leq \Delta \cdot \tau_i, \quad \forall i \in \mathbf{S}; \quad (5)$$

$$1 - \sum_{k \in \mathbf{T}_s} \pi_i^k \leq \Delta \cdot \tau_i, \quad \forall i \in \mathbf{S}; \quad (6)$$

$$\Phi_i \leq \Delta \cdot (1 - \tau_i), \quad \forall i \in \mathbf{S}; \quad (7)$$

$$l_i^s = \sqrt{(x_i^s - x_0)^2 + (y_i^s - y_0)^2}, \quad \forall i \in \mathbf{S}; \quad (8)$$

$$l_i^j = \sqrt{(x_i^s - x_j^o)^2 + (y_i^s - y_j^o)^2}, \quad \forall i \in \mathbf{S}, \quad j \in \mathbf{U}; \quad (9)$$

$$(l_i^s + l_i^j) - l_i^{\max} \leq \Delta \cdot \xi_i^j, \quad \forall i \in \mathbf{S}, \quad j \in \mathbf{U}; \quad (10)$$

$$l_i^{\min} - (l_i^s + l_i^j) \leq \Delta \cdot \zeta_i^j, \quad \forall i \in \mathbf{S}, \quad j \in \mathbf{U}; \quad (11)$$

$$\Psi_i^j \leq \Delta \cdot (1 - \xi_i^j), \quad \forall i \in \mathbf{S}, \quad j \in \mathbf{U}; \quad (12)$$

$$l_i^{\max} \leq l_{\max}^{\text{total}}, \quad \forall i \in \mathbf{S}; \quad (13)$$

$$l_i^{\max} - l_i^{\min} \leq l_{\max}^{\text{diff}}, \quad \forall i \in \mathbf{S}. \quad (14)$$

In the model, the total cost is made up of three parts. The first part is the cost of OLTs, as each splitter corresponds to a PON, which requires an OLT. The second part is the cost of splitters, and the last part includes the cost for trenching and laying fibers and the cost of fiber cables.

Constraint (2) says that each ONU must connect to a splitter. Constraint (3) determines whether the  $i$ th splitter should be deployed, which depends on whether there are any ONUs connected to the splitter. If there are any, the splitter must be deployed; otherwise, not deployed.<sup>4</sup> Constraint (4) selects a splitter type, which ensures that the splitter has sufficient outlet ports to connect to all the ONUs.

Constraints (5)–(7) ensure an *if-then* condition. If the  $i$ th splitter is selected, there must be only one splitter type associated with the splitter. More specifically, if  $\Phi_i = 1$  (i.e., the  $i$ th splitter is selected), then  $\tau_i = 0$  must hold, which further leads to  $\sum_{k \in \mathbf{T}_s} \pi_i^k = 1$  due to constraints (5) and (6) (i.e., there is a single splitter type for the  $i$ th splitter). Constraint (8) computes the distance from a splitter to the central OLT. Constraint (9) computes the distance from a splitter to an ONU. These two constraints are nonlinear, which makes the whole optimization model nonlinear as well.

Constraints (10)–(12) find the maximal distance and the minimum distance between an ONU and an OLT, respectively, within each PON. The constraints are also based on an *if-then* condition. If  $\Psi_i^j = 1$  (i.e., the  $j$ th ONU is associated with the  $i$ th PON or split-

ter), then  $\xi_i^j = 0$  must hold, which thus derives constraints (10) and (11) into  $l_i^s + l_i^j \leq l_i^{\max}$  and  $l_i^{\min} \leq l_i^s + l_i^j$ , respectively.

Constraint (13) ensures that the maximal transmission distance of a PON is not exceeded. Constraint (14) ensures that the maximal differential distance between different ONUs within the same PON network is satisfied.

### C. Discussion

The whole optimization problem can be divided into three subproblems, i.e., (i) determining the total number of required PONs (i.e., splitters); (ii) associating ONUs to splitters, which is termed the *ONU-splitter association* subproblem, i.e., clustering ONUs into groups that connect to common splitters; and (iii) relocating the positions of the splitters that achieve the optimal cost, which is termed the *splitter relocation* subproblem. The three subproblems entangle with each other. We need to jointly solve them to obtain an optimal solution to the whole problem.

In the first subproblem, the total number of required PONs or splitters cannot be determined in advance. The only way to evaluate the required number of PONs or splitters that minimizes the total cost is to enumerate all possible partition patterns of ONUs and then determine the optimal splitter location for each ONU cluster. The computation complexity of this brute-force search increases factorially with the total number of ONUs, which is prohibitive for a large number of ONUs.

The ONU-splitter association subproblem, i.e., subproblem (ii), attempts to find an optimal association between ONUs and splitters, providing that the locations of the splitters are given, i.e., the variables  $x_i^s$ ,  $y_i^s$ ,  $\Phi_i$ ,  $l_i^s$ , and  $l_i^j$  all become given parameters. With these given parameters, the previous optimization model becomes a mixed integer linear programming (MILP) model. Though it is possible to find an optimal association for a medium-size planning scenario, the subproblem is still NP-complete, which is intractable for a large planning scenario.

The third subproblem determines splitter locations for each PON such that the total fiber length, which is the sum of the fiber lengths from each ONU to the splitter, is minimum.<sup>5</sup> This relocation problem is well-known as the Fermat–Weber point problem (FWPP) [12], which is a nonlinear optimization problem and whose objective function is convex, but not everywhere differentiable [13]. Several algorithms are available to solve the problem. One of them is the

<sup>4</sup>If there is only a single ONU connected to a splitter in the optimization results, we will manually remove the splitter from the results as no splitter is required to connect a single user to an OLT.

<sup>5</sup>Because the cost of trenching and laying fibers is generally much more expensive than other costs such as OLT and splitter costs, we consider minimizing the fiber length as a key objective when locating an optical splitter.

Weiszfeld algorithm [12,13]. We will adopt this algorithm as a subroutine in our subsequent heuristic.

In addition, the current optimization problem relates to the well-studied classical problem, called the multifacility location-allocation problem (MLAP), which was introduced by Cooper [14] in operations research. The MLAP aims to select the positions of distributed warehouses, such that the total cost (usually represented by a Euclidean distance) to serve a set of given service centers is minimal, if each service center is served by one and only one distributed warehouse. Despite the similarity, the fiber deployment problem that we consider here does show major differences from the classical MLAP in several aspects as follows.

First, the fiber deployment problem is subject to the maximal transmission distance and the maximal differential distance of a PON, while in the MLAP, there are no such corresponding constraints. Second, in the fiber deployment problem, the required number of splitters is not given in advance, which actually is a part of the solution to be determined, while the number of required distributed warehouses is given and fixed in the MLAP. Finally, the splitter capacity is limited in the fiber deployment problem, while the classical MLAP allows warehouses to serve any number of service centers. Thus, based on the above comparison, the fiber deployment problem that we attempt to solve is even more difficult than the classical MLAP.

### III. HEURISTIC ALGORITHMS

We propose two heuristics to solve the above PON deployment problem. One is based on an intuitive random-cut sectoring approach, which is simple and used for performance comparison. The second is called the Recursive Association and Relocation Algorithm (RARA), which employs a recursive process to keep on executing the subroutines of ONU-splitter association and splitter relocation until an optimal (at least locally minimal) solution is found. Because among all the PON deployment costs, the cost of trenching and laying fibers is the most expensive, which overwhelms all the other costs in the whole deployment, in both of the heuristics we have taken the total distance of trenching and laying fibers as a major minimization objective.

#### A. Random-Cut Sectoring Algorithm

Like cutting a cake, the random-cut sectoring algorithm partitions all the ONUs into equal-size groups according to their geometric positions. The size of each group is equal to the maximal optical split ratio. After the partitioning, Weiszfeld’s algorithm [12,13] is then

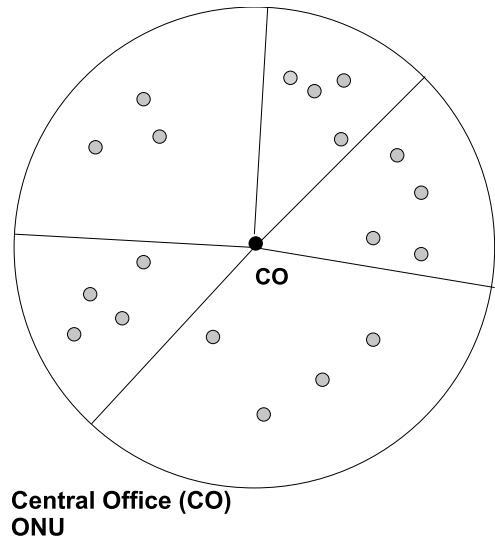

Fig. 2. (Color online) An example of the random-cut sectoring approach.

applied to find the optimal splitter position for each PON. Finally, all the ONUs in the same groups connect to common splitters.<sup>6</sup>

Figure 2 illustrates an example of the above sectoring approach. Given a set of disperse ONUs and an optical split ratio 1:4. We start from the positive direction of the vertical axis, which is randomly selected, and rotate the radius line in the clockwise direction for ONU grouping. A radius line is drawn when four ONUs are included in the current section. The rotation will continue until all the ONUs are grouped or clustered.

#### B. Recursive Association and Relocation Algorithm (RARA)

The Recursive Association and Relocation Algorithm (RARA) is extended from Cooper’s algorithm [15], which has been used to solve the MLAP in logistics studies. The flowchart of RARA is shown in Fig. 3.

The left column implements an outer loop, which consists of several steps. Step 1 randomly generates an initial set of splitters, i.e., a set of locations. To find the best design, the size of the initial splitter set  $s$  will take all the values from a minimum value,  $S_{\min}$ , to a maximal value,  $S_{\max}$ .  $S_{\min}$  equals the minimum required number of splitters to connect all the  $|\mathbf{U}|$  ONUs, i.e.,  $S_{\min} = \lceil |\mathbf{U}|/n \rceil$ , where  $1:n$  is a maximal allowed split ratio.  $S_{\max}$  is set to be the total number of ONUs,  $|\mathbf{U}|$ , which corresponds to an extreme case that each splitter connects to a single ONU. Furthermore,

<sup>6</sup>If the total number of ONUs is not an integer multiple of the split ratio, the number of ONUs in the last group is less than the split ratio. Also, no system constraints such as maximal PON reach and maximal PON differential difference are considered in this simple algorithm. For real deployment, a further step is required to verify whether each of the planned PONs meets the system constraints.

to avoid falling into a local minimum, for each specific splitter set size  $s$ , which is a value within the range from  $S_{\min}$  to  $S_{\max}$ , we randomly generate  $N$  different initial splitter sets (splitters positions). These  $N$  sets of initial splitters correspond to an  $i$  loop from  $i=1$  to  $i=N$  in Fig. 3. In total, there are  $N(S_{\max}-S_{\min}+1)$  initial sets of splitters that are evaluated as starting points in the searching algorithm. For example, if we set  $S_{\min}=30$ ,  $S_{\max}=480$ , and  $N=100$ , then the algorithm evaluates a total of 45,100 initial sets of splitters as starting points.

Step 2 validates whether the current initial set of splitters can meet all the PON system constraints, including maximal transmission distance, maximal differential distance, and optical split ratio, if they are used to connect all the ONUs. If the set is valid, the algorithm calls a recursive process, i.e., Step 3, to use the initial set of splitters as a starting point to find the best (often a smaller) set of splitters and their corresponding locations. For example, the current initial splitter set may contain 100 splitters. After the recursive step, i.e., Step 3, the total number of splitters may be tuned down to 80 while all the ONUs can still be connected to their corresponding splitters without breaking the PON system constraints.

The middle column in Fig. 3 shows the detail of the recursive (searching) process. Specifically, the process first calls an “ONU-splitter association and splitter relocation” step (i.e., Step 4), which is termed the A/R step. The detail of the A/R step is shown in the right column of Fig. 3, which employs an ONU-splitter association step (i.e., Step 7) and splitter relocation steps (i.e., Steps 8 and 9) to find the (minimal) required number of splitters and their best locations, and the association relationship between the ONUs and the splitters. We will introduce the detail of the steps of *ONU-splitter association* and *splitter relocation* later.

Based on the returned set of splitters and the association relationship between the ONUs and the splitters from Step 4, which essentially is a PON network planning, we can evaluate the optimality of the result by calculating the total cost if the PONs are deployed in this way. This cost includes all the sub-costs described in Section II.A and is compared to the current best known cost in Step 5. The best known cost is based on a previous good design. If the new cost is better than the current best known cost, then we update the new cost as the current best known cost and record the current PON network planning. Meanwhile, if the two costs are very close (within a predefined difference range), we say the searching process is converged, and stop the recursive process and return the result to Step 3. Otherwise, we will repeat Steps 4 and 5 until either the total cost is eventually converged or a predefined number  $R$  of iterations are

performed. For the latter case, i.e., a non-converged situation, we further employ a simulated annealing (SA)-like process (i.e., Step 6) to finalize a (good) solution. The detail of this SA-like algorithm is introduced next.

We describe the three key steps, i.e., Steps 6, 7, and 8, in the RARA heuristic as follows.

1) *ONU-splitter association*: The ONU-splitter association step (i.e., Step 7) is important to the whole heuristic to find an optimal association between ONUs and splitters, subject to the PON system constraints. Given the location of each splitter, it is possible to employ the aforementioned mixed integer linear programming (MILP) model to find optimal solutions. The MILP model essentially carries out an efficient exhaustive search. However, the *association* problem itself is NP-complete, which is intractable for a large size planning scenario. Thus, in the RARA algorithm we employ a heuristic subroutine to determine the association.

The association process first finds a pair of ONU and splitter, which has the shortest distance among all the ONU-splitter pairs. Then, three PON system constraints including optical split ratio, maximal transmission distance, and maximal differential distance, are verified for the selected ONU-splitter association. If the association is valid, we keep it and move on to the next pair of ONU and splitter that has the shortest distance among all the remaining unconnected ONUs, and the same verification is performed. Such a process is repeated until all the ONUs find their associated splitters.

Particularly, if a “Calendar” data structure [16] is employed to store the pairs of ONUs and splitters, the required computation complexity of the above ONU-splitter association process is on the order of  $O(m^2)$ , where  $m$  is the total number of ONUs, i.e.,  $m=|U|$ .

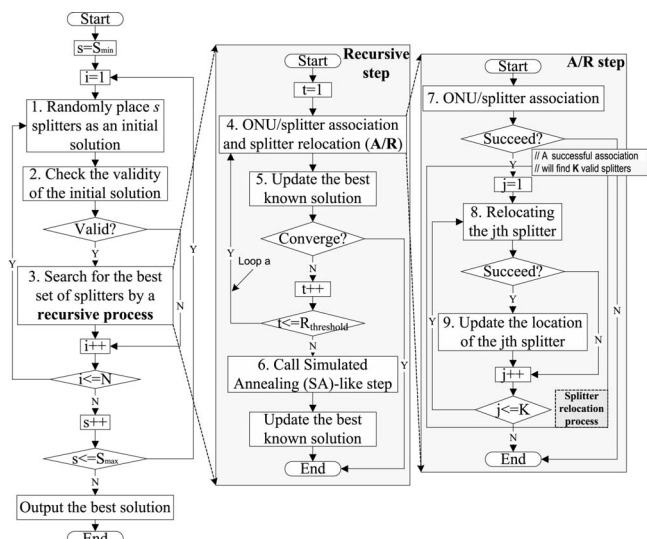

Fig. 3. Flowchart of RARA [1].

2) *Splitter relocation*: The ONU-splitter association step divides the whole group of ONUs into several small groups with each corresponding to a PON. Based upon these ONU groups, the next step (i.e., Step 8) is to find the best location of the optical splitter for each PON. The problem is essentially to find a Fermat–Weber point for a polygon with a group of ONUs and an OLT as vertices [12]. We extended the traditional Weiszfeld’s algorithm (see Appendix A) to search such a splitter location in a continuous space. In particular, when applying Weiszfeld’s algorithm, we need to ensure the PON system constraints including maximal transmission distance and maximal differential distance. The output of the relocation step will be the best location of the splitter for the current group of ONUs and the associated OLT.

3) *Simulated annealing (SA)-like subroutine*: There is a key loop (i.e., loop **a**) in the middle column of Fig. 3. The loop stops whenever a solution to a set of splitters is converged. However, sometimes the loop may fail to converge after  $R$  iterations, but enter a deadlock between two or even more local minimum solutions. Under these circumstances, we need to find a way to resolve the deadlock. For this purpose, we propose a simulated annealing-like subroutine for the RARA algorithm, i.e., Step 6.

Specifically, when a deadlock occurs, the SA-like subroutine is called to repeat the A/R step (i.e., Step 4). The subroutine stores two variables. One is the best solution during the whole simulated annealing process, and the other is the current solution. In each iteration, if the new found solution is better than the current best one, then the new solution substitutes for the current best one, as well as the current solution; otherwise, a random number between the interval of  $[0, 1]$  is generated and compared with a temperature function, which is updated in each iteration. The new solution is also accepted as the current solution if the random number is less than the temperature function value. The whole subroutine stops when the temperature function is less than a predefined small threshold.

### C. Maximal Sharing of Cable Conduit

In RARA, an important assumption is postulated that an independent cable conduit is built for each fiber link between an ONU and a splitter. It is possible to further tune down the deployment cost by allowing a fiber link to traverse the cable conduits that have been built for other fiber links, which is called *sharing of cable conduits*.

As shown in Fig. 4, there are three PONs in the deployment. We take PON 2 as an example to illustrate the concept of cable conduit sharing. Rather than building a cable conduit directly for the fiber links between the splitter and ONUs B and C, respectively, we

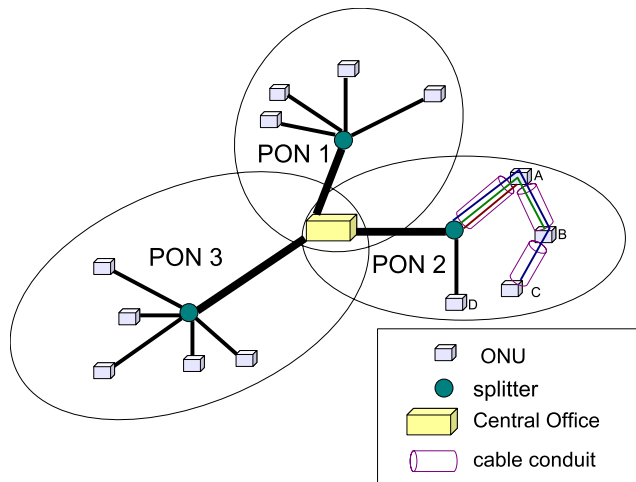

Fig. 4. (Color online) Concept of cable conduit sharing in PON networks.

may build a cable conduit from A to B and from B to C and then use the consecutive conduits from the splitter to A and from A to B to lay fibers for the link between the splitter and B. Similarly, we can use the consecutive conduits from the splitter to A, from A to B, and from B to C, to lay fibers for the link between the splitter and C. By doing so, the trenching cost for laying fibers can be significantly reduced, compared to independent trenching for each ONU-splitter link.

To exploit the potential benefit of conduit sharing, we develop an enhanced algorithm subsequent to the design obtained by RARA. Specifically, for each PON, the algorithm considers each of the locations (including the splitter and each of the ONUs) as a vertex and employs an extended minimum spanning tree algorithm, similar to Prim’s algorithm [17], to find a *constrained* minimum spanning tree that connects all the locations. Different from a pure minimum spanning tree, we need to ensure the PON system constraints, such as maximal transmission distance, when finding the minimum spanning tree.

## IV. SIMULATION CONDITIONS AND TEST SCENARIOS

To evaluate the efficiency of the proposed approaches, we conducted extensive simulation studies. The following conditions are assumed in the simulations. First, the number  $N$  in the flowchart shown in Fig. 2 is initially set to be 500. That is, for each given number  $s$  of splitters, we generate 500 different instances of splitter set in size  $s$ . Second, the available maximal split ratios are 1:4, 1:8, 1:16, 1:32, and 1:64. A maximal split ratio constrains how many ONUs can be connected to a common PON. For example, if the maximal split ratio is 1:32, which means that up to 32 ONUs can be connected to a single PON. However, it should be noted that the parameter of maximal split

ratio does not require us to always use the maximal-size splitter. For example, if there are only 11 ONUs connected to a PON, then a smaller splitter with a ratio of 1:16, instead of 1:32, can be used for cost saving. Third, the following cost factors are assumed for the simulations: the cost of trenching and laying fiber is \$16,000/km, the cost of fiber cables is \$4,000/km, the cost of each OLT is \$2,500, and the cost of each splitter port is \$100.

Three PON network planning scenarios are considered, including (i) a circle with a 16 km radius, (ii) an annulus with a 16 km inner circle radius and a 50 km outer circle radius, and (iii) a circle with a 50 km radius. The region of scenario (iii) is essentially made up of the regions of scenarios (i) and (ii). Within each of the scenario regions, we assume that all ONUs are randomly distributed.

Practically, scenario (i) corresponds to a situation that all the users are close to the central office, which therefore requires only short-reach PONs, while scenario (ii) represents a case that all the users are far away from the central office, thereby requiring long-reach PONs. The last scenario corresponds to the situation that we do not distinguish close or far users, but use the same type of (long-reach) PONs to connect all the users.

In scenario (i), we planned for the cases with different numbers of ONUs ranging from 100 to 500 ONUs with 100 ONUs for each step increase. Note that when making a step increase of ONUs, the locations of the existing ONUs are not changed. That is, based on the existing ONUs, the new ONUs are just randomly added and evenly distributed. The EPON system standard is applied for this scenario, which is subject to the system constraints of 20 km maximal transmission distance and 20 km maximal differential distance.

In scenario (ii), we considered the cases with the numbers of ONUs ranging from 300 to 700 also with 100 ONUs for each step increase. In this scenario the system constraints of GPON are applied, which are subject to 60 km maximal transmission distance and 20 km maximal differential distance.

Finally, the numbers of ONUs in scenario (iii) ranges from 600 to 1000 also with 100 ONUs for each step increase. The locations of the ONUs in scenario (iii) are actually the combinations of the previous two scenarios. We combined the case of 300 ONUs of scenario (i) with all the cases ranging from 300 to 700 ONUs of scenario (ii) to form all the cases of scenario (iii). For example, the case of 700 ONUs is formed by a combination of the case of 300 ONUs of scenario (i) and the case of 400 ONUs of scenario (ii). Also, for scenario (iii), the system constraints of GPON are applied, which are subject to 60 km maximal transmis-

sion distance and 20 km maximal differential distance.

## V. RESULTS AND ANALYSES

### A. Comparison of Different Approaches

In this section, we compare the performance of different planning approaches. Figure 5 shows how the total cost changes with the total number of ONUs under a maximal split ratio of 1:16 for scenario (i). We can see that the RARA approach can achieve a much better performance, i.e., lower cost, than the random-cut sectoring approach. Moreover, RARA shows better efficiency with the increase of the total number of ONUs. Also, comparing the results of cable conduit sharing and non-sharing (i.e., with MST and without MST in the legends), we can see that cable conduit sharing can help to significantly reduce the cost of PON deployment. The cost reduction also increases with the increase of the total number of ONUs. We also conducted similar simulations for other maximal split ratios, and similar results were observed.

To highlight the significance of the RARA and cable conduit sharing, we also compare two extreme cases, i.e., the sectoring approach without cable conduit sharing, i.e., Sectoring, and the RARA approach with cable conduit sharing, i.e., RARA+MST. It can be found that the RARA approach and the effort of conduit sharing can jointly bring about 50% cost reduction for a network design with 500 ONUs.

Figures 6 and 7 show the results for the annulus scenario, i.e., scenario (ii), and the large circular scenario, i.e., scenario (iii), respectively. Similar observations are made to those of the small circular scenario. Specifically, the sectoring approach without MST per-

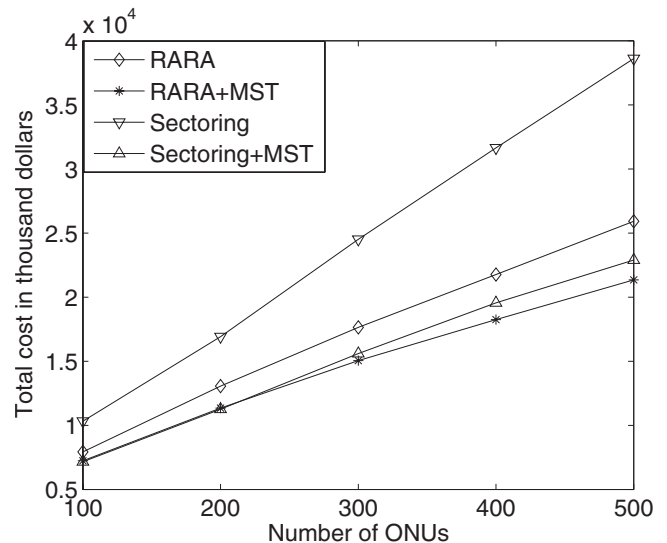

Fig. 5. Total cost vs. number of ONUs, circular scenario, radius = 16 km, maximal split ratio = 1:16.

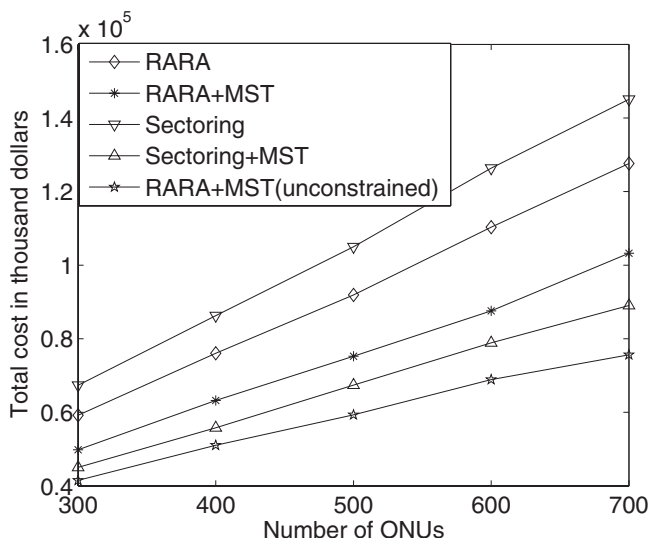

Fig. 6. Total cost vs. number of ONUs, annulus scenario, maximal split ratio=1:16.

forms worst, and the RARA approach with MST and without PON system constraints (i.e., allowing any maximal transmission distance and maximal differential distance) performs best.

In particular, for the annulus scenario, it seems abnormal (actually not abnormal) that the approach of Sectoring+MST outperforms the approach of RARA+MST. This is because the sectoring approach does not consider the PON system constraints (including maximal transmission distance and maximal differential distance), while the RARA approach always takes these constraints into account. To evaluate the effectiveness of the RARA approach, we also show the results of RARA+MST without considering the system constraints, i.e., RARA+MST (unconstrained), which as shown significantly outperforms the approach of Sectoring+MST.

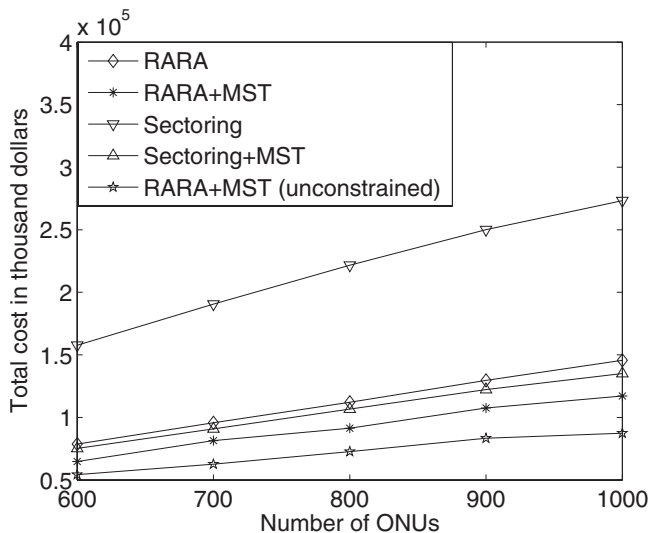

Fig. 7. Total cost vs. number of ONUs, circular scenario, radius = 50 km, maximal split ratio=1:16.

### B. Impact of Maximal Optical Split Ratio

Maximal optical split ratio is an important system parameter that affects the deployment cost of PONs. Figures 8 and 9 show how the average PON deployment cost per user changes with different maximal optical split ratios under the small circular scenario, i.e., scenario (i), and the annulus scenario, i.e., scenario (ii). As shown in Fig. 8, in addition to the similar performance ranks of the curves as reported in Section V.A, we can see that the average cost per user decreases with the increase of maximal optical split ratio. This is because a larger optical split ratio enables a single splitter to accommodate more ONUs, thereby more efficiently sharing the feeder fiber from a central OLT to the splitter.

On the other hand, it is interesting to see that there is a saturating trend with the increase of maximal optical split ratio. When the split ratio is small, an increase of the split ratio can significantly reduce the deployment cost per user, e.g., up to 40% from a ratio of 1:4 to a ratio of 1:16. However, if the split ratio has reached a certain level, a further increase does not bring much reduction to the deployment cost. As shown in Fig. 8, the cost reduction from the split ratio of 1:16 to 1:32 is marginal. Similar observations can be found for the annulus scenario as shown in Fig. 9, in which the cost per user decreases with the increase of split ratio, until it approaches a saturation split ratio of 1:32. It should be noted that the saturating threshold value changes with the ONU density. In general, a higher optimal split ratio can be expected for a higher ONU density.

### C. Impact of Maximal PON Transmission Distance

The maximal transmission distance of a PON is another important system constraint that shows impact

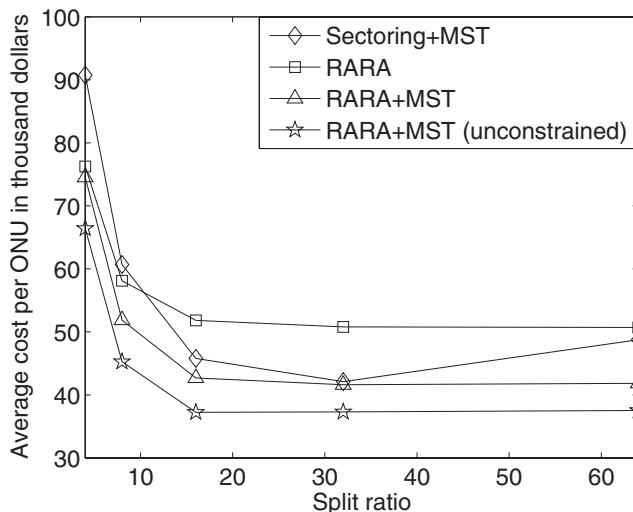

Fig. 8. Average cost per user vs. split ratio, circular scenario, radius=16 km, number of ONUs=500.

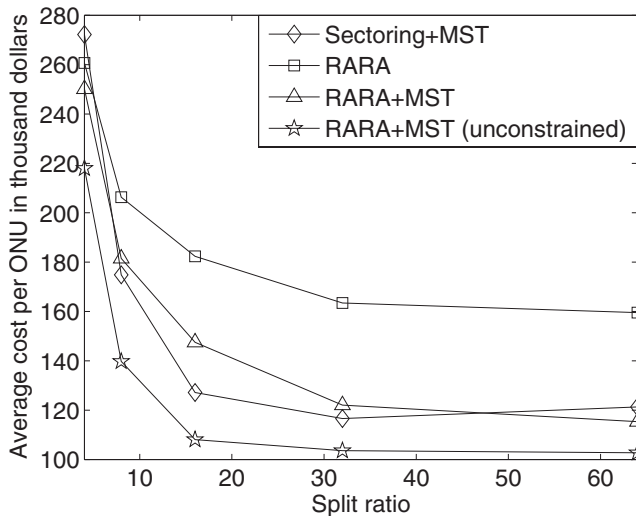

Fig. 9. Average cost per user vs. split ratio, annulus scenario, number of ONUs=700.

on the total deployment cost. To evaluate the impact, the following test conditions were assumed. We consider the small circular scenario with radius=16 km. 400 ONUs are assumed to be uniformly randomly distributed within the circle. The allowed maximal optical split ratios include 1:4, 1:16, and 1:64. The maximal differential distance is 20 km. The maximal PON transmission distances are configured to change among 16, 18, 20, 24, and 30 km.

Figure 10 shows how the total PON deployment cost changes with the increase of the PON maximal transmission distance under the RARA approach with cable conduit sharing. It is not surprising to see that the total cost decreases with the increase of the maximal transmission distance, as a longer maximal transmission distance provides more flexibility and optimization opportunities for the design. Also, it is interesting

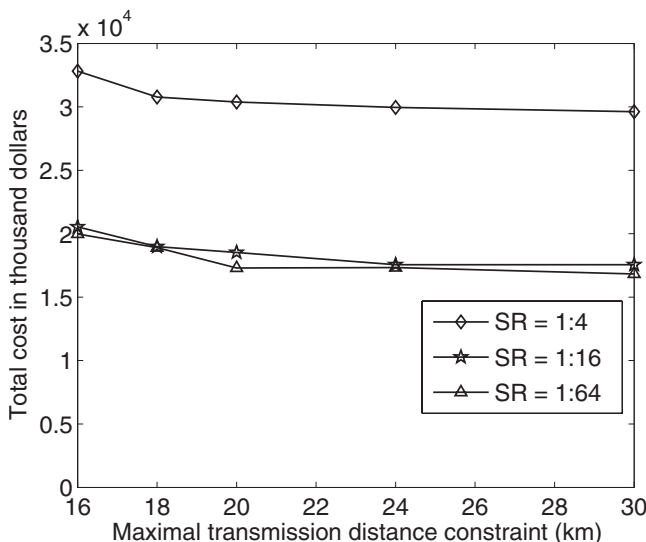

Fig. 10. Total cost vs. maximal PON transmission distance, circular scenario, radius=16 km, ONU number=400.

to see that there is a saturating trend, which shows a marginal total cost reduction after the maximal transmission distance has been extended to a certain range. Specifically, for the current design scenario, such a saturation distance is around 20 km, which implies that after 20 km, a further increase of maximal transmission distance will not bring much reduction in the total cost. It is reasonable since once a transmission distance is sufficient to cover all the users, it would not bring any benefit even if the maximal transmission distance is further increased.

D. Impact of Maximal Differential Distance

The maximal differential distance of a PON can also affect the total deployment cost. To evaluate this effect, we again design the test scenarios as follows. We consider the smaller circle scenario, i.e., scenario (i), with 400 ONUs uniformly randomly distributed. The maximal PON transmission distance is set to be 20 km. The maximal optical split ratio is assumed to change among 1:4, 1:16, and 1:64. Finally, the maximal differential distance is assumed to range from from 4 km to 20 km with 4 km increase for each step.

Figure 11 shows how the total network costs change with the increase of maximal differential distance under the RARA+MST approach. It can be found that the increase of maximum differential distance can bring some reduction of the total deployment cost, which is, however, very marginal. The result thus implies that the total PON deployment cost seems not to be sensitive to the change of the maximal differential distance. This is reasonable because all the ONU users that are connected to a common splitter are often close to each other, which does not require a large maximal differential distance.

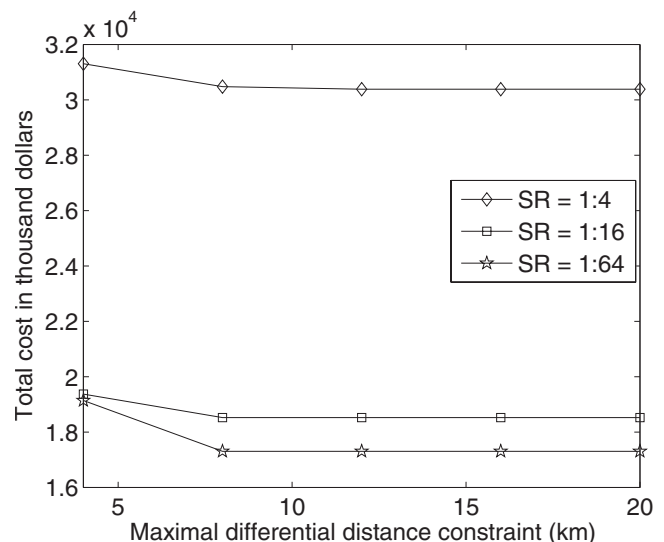

Fig. 11. Total cost vs. maximal differential distance, circular scenario, radius=16 km, ONU number=400.

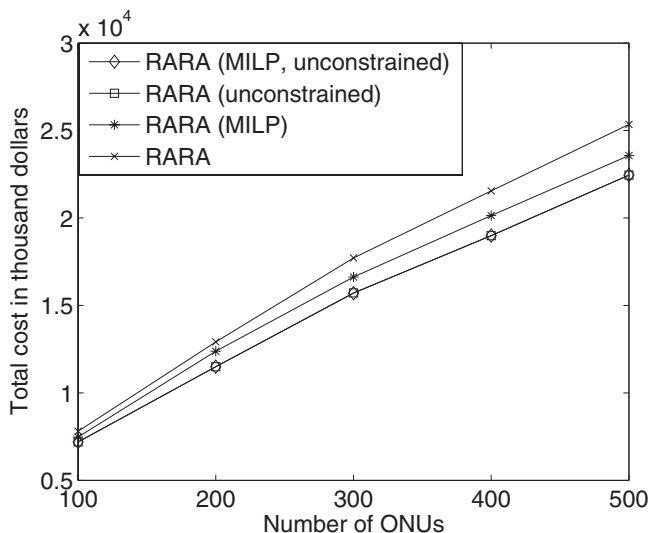

Fig. 12. Comparison of the ONU-splitter association algorithm in RARA and the MILP model for the circular planning scenario with radius=16 km, split ratio=1:64.

*E. Effectiveness of ONU-Splitter Association Algorithm*

In the RARA approach, there is an important step that associates ONUs to splitters given a specific set of splitters. For the association, in addition to the heuristic subroutine as proposed in RARA, we employ the MILP model described in Section II.B (ignoring constraints (8) and (9)) to find an optimal solution for a medium-size planning scenario, e.g., with up to hundreds of ONUs. This posterior MILP optimization is termed RARA+MILP. It is carried out based on the results found by the RARA heuristic, in which a list of splitters have been found. We used the commercial software package AMPL/CPLEX to solve the MILP optimization model. We consider the small circular scenario, i.e., scenario (i), as a study case, in which the total number of ONUs is no greater than 500 and the maximal split ratio is 1:64.

Figure 12 compares the total costs of the two designs, i.e., pure RARA vs. RARA with the posterior MILP optimization (RARA+MILP). It is found that without considering the PON system constraints including maximal transmission distance and maximal differential distance, the pure RARA algorithm can achieve almost the same performance as that of RARA+MILP. Their relative performance difference is less than 1%. When the PON system constraints are considered, the pure RARA algorithm still performs well, close to that of RARA+MILP. Their relative difference is consistently less than 10%. These results thus verify that the ONU-splitter association algorithm used in RARA is efficient, which can achieve good solutions, close to the optimal results obtained by the MILP optimization.

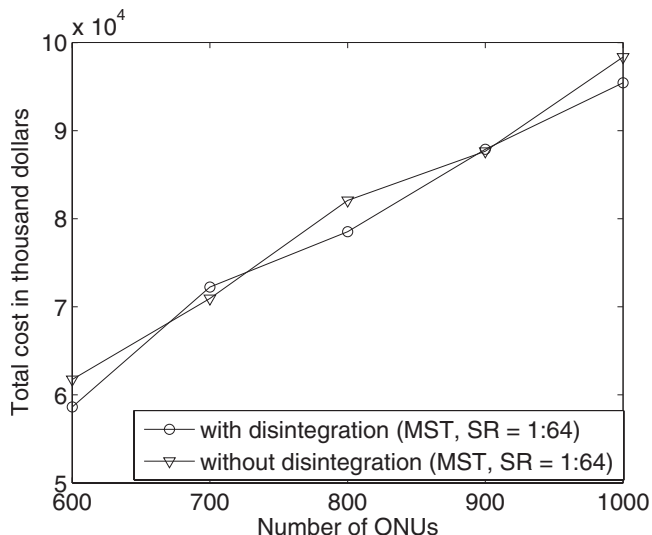

Fig. 13. Total cost of the planning with disintegration and without disintegration, SR, split ratio

*F. Disintegrating Large PON Planning Scenarios*

RARA+MST is efficient and fast for the design scenarios containing several hundreds of ONUs. However, for a very large planning scenario with thousands or several thousands of ONUs, the computation time of RARA+MST is prohibitive. To shorten the computation time, one effective way is to divide a large planning scenario into several smaller ones. For example, given a large circle containing 1400 ONUs, we may divide this large circle into two parts, including one small circle containing 700 ONUs and one outer annulus containing the remaining 700 ONUs. Then we apply the approaches proposed in the study to solve the two smaller scenarios and sum them up to find an overall solution to the large circular scenario. By doing this, we expect that the overall computation time can be significantly reduced, while the design performance is still close to the design without such disintegration.

In our study, scenario (iii) is essentially made up of the combinations of the cases of the small circular area, i.e., scenario (i), and the cases of the outer annulus, i.e., scenario (ii). To evaluate the effectiveness of the proposed disintegration method, we compare the solutions to scenario (iii) with the sums of the solutions to scenarios (i) and (ii).

Under the RARA+MST approach, Fig. 13 shows the total costs of the designs without disintegration, i.e., scenario (iii), and the designs with disintegration, i.e., the sums of scenarios (i) and (ii). We can see that the results without disintegration and with disintegration are very close, while the latter requires much shorter computation times. As shown in Table I, the approach with disintegration requires only 20% of the time of

TABLE I  
COMPARISON OF COMPUTATION TIMES (HOURS) OF THE APPROACHES WITH DISINTEGRATION AND WITHOUT DISINTEGRATION (600 ONUS)

Optical split ratio	Computation Times (hours)				
	1:4	1:8	1:16	1:32	1:64
With disintegration	4.93	6.16	7.06	7.93	8
Without disintegration	23.33	31.05	32.77	37.17	34.21

that required by the approach without disintegration when planning a PON network with 600 ONUs. The results therefore verify that the disintegration method is effective for large-size PON deployment.

## VI. CONCLUSION

We plan greenfield PON networks to minimize their total deployment costs. A mathematical optimization model is developed, which is intractable due to its nonlinearity and NP-complete feature. Thus, we propose an efficient heuristic called RARA to find sub-optimal solutions to the problem. Due to the dominant cost of trenching and laying fibers, we also exploit the benefit of cable conduit sharing among different fiber links to further tune down the deployment cost. The simulation studies indicate that the RARA approach is efficient to significantly reduce PON deployment cost compared to a random-cut sectoring approach. The simulation studies also show that the effort of cable conduit sharing can bring up to 20% cost saving compared to the pure RARA approach.

We also evaluate the effects of PON system constraints, including maximal optical split ratio, maximal transmission distance, and maximal differential distance. Saturating trends of the PON deployment cost are observed in PON network planning when increasing the three system parameters. In addition, the efficiency of the ONU-splitter association subroutine in RARA is evaluated. It is found that the proposed association heuristic is efficient to perform closely to the MILP approach.

Finally, to shorten the computation time of a large-PON network design, we develop an approach to disintegrate a large size planning scenario into several small scenarios. It is found that the disintegration effort can significantly reduce the planning time while no significant performance is sacrificed.

As a limitation, the current study has considered a simplified greenfield PON network deployment, in which only PON system constraints were taken into account. A more comprehensive future study can also consider other constraints such as existing routing/conduits. Moreover, while a single-stage splitter per PON is a valid assumption, multi-stage PONs are an

other interesting topic that shows practice in real PON deployment. As a first-cut of PON network planning, we hope this article will spark new research interest in the field.

## ACKNOWLEDGMENT

The authors would like to thank Marcus Voltz for the discussion of Weiszfeld's Algorithm, and the Australian Research Council (ARC) for supporting this research.

## APPENDIX A. WEISZFELD'S ALGORITHM

Weiszfeld's algorithm is an iterative reweight least square method, which computes the position of the geometric median, also known as the Fermat–Weber point, for a convex polygon. Though the complexity of the Fermat–Weber problem itself is not known [12], the Weiszfeld algorithm is proved to be efficient in practice, especially for a small-scale problem. The algorithm is proved to be convergent in linear time. The pseudo-code of Weiszfeld's algorithm is given below:

### Algorithm 1 Weiszfeld Algorithm [12]

**Input:** Set of ONUs  $\mathbf{U}$ ;

```

1:   for  $i = 1$  to  $|\mathbf{U}|$  do
2:       if  $\|\sum_{\vec{v} \in \mathbf{U} \setminus \vec{v}_i} \frac{\vec{v} - \vec{v}_i}{\|\vec{v} - \vec{v}_i\|}\| \leq 1$  then
3:           return  $\vec{v}_i$ 
4:       Select initial solution  $x_0$  inside the convex hull
       form by  $\mathbf{U}$ .
5:       repeat
6:            $\vec{x}_{k+1} = \sum_{\vec{v} \in \mathbf{U}} \frac{\vec{v}}{\|\vec{v} - \vec{x}_k\|} / \sum_{\vec{v} \in \mathbf{U}} \frac{1}{\|\vec{v} - \vec{x}_k\|}$ 
7:       Until  $\|\vec{x}_k - \vec{x}_{k+1}\| \leq \epsilon$ 
8:       return  $\vec{x}_{k+1}$ 

```

In the algorithm,  $|\mathbf{U}|$  stands for the cardinality of set  $\mathbf{U}$ .  $\vec{v}$  corresponds to an ONU in  $\mathbf{U}$ , which is a two-dimensional vector embedding the coordinates of the ONU. The **for** loop (i.e., lines 1–3) is a procedure to check whether the Fermat–Weber point coincides with any of the ONU positions. The procedure of the **repeat-until** loop (i.e., lines 5–7) is an iterative step to find the Fermat–Weber point, providing that the point does not coincide with any of the ONU positions. The subscript  $k$  of  $\vec{x}_k$  is an iteration counter.

## REFERENCES

- [1] J. Li and G. Shen, "Cost minimization planning for passive optical networks," in *Proc. OFC/NFOEC 2008*, Feb 2008.
- [2] G. Kramer, B. Mukherjee, and G. Pesavento, "IPACT: a dynamic protocol for an Ethernet PON (EPON)," *IEEE Commun. Mag.*, vol. 40, no. 2, pp. 74–80, Feb. 2002.
- [3] F. Effenberger, D. C. Calix, G. Kramer, R. Li, M. Oron, and T. Pfeiffer, "An introduction to PON technologies," *IEEE Commun. Mag.*, vol. 45, no. 3, pp. S17–S25, Mar. 2007.
- [4] "Ethernet in the First Mile," *IEEE 802.3ah*, June 2004.

- [5] ITU-T G.984.1, SG 15, "Gigabit-capable Passive Optical Networks (G-PON): General Characteristics," March 2003.
- [6] ITU-T G.984.4, SG 15, "Gigabit-capable Passive Optical Networks (G-PON): Transmission Convergence Layer Specification," July 2005.
- [7] C. M. Assi, Y. Ye, S. Dixit, and M. A. Ali, "Dynamic bandwidth allocation for quality-of-service over Ethernet PONs," *IEEE J. Sel. Areas Commun.*, vol. 3, no. 9, pp. 1467–1477, Nov. 2003.
- [8] C. H. Foh, L. Andrew, E. Wong, and M. Zukerman, "FULL-RCMA: a high utilization EPON," *IEEE J. Sel. Areas Commun.*, vol. 22, no. 8, pp. 1514–1524, 2004.
- [9] G. C. Gupta, M. Kashima, H. Iwamura, H. Tamai, T. Ushikubo, and T. Kamijoh, "Over 100 km bidirectional, multi-channels COF-PON without optical amplifier," in *OFC 2006*, paper PDP51.
- [10] "10 GEAPON IEEE Working Group," <http://www.ieee802.org/3/av/index.html>, online on September 18, 2007.
- [11] M. Hajduczenia, B. Lakic, H. J. A. Da Silva, and P. P. Monteiro, "Optimized passive optical network deployment," *J. Opt. Netw.*, vol. 6, no. 9, pp. 1079–1104, 2007.
- [12] D. Cieslik, *Steiner Minimal Trees*, Kluwer Academic Publishers, 1998.
- [13] H. W. Kuhn and R. E. Kuenne, "An efficient algorithm for the numerical solution of the generalized Weber problem in spatial economics," *J. Regional Sci.*, vol. 4, no. 2, pp. 21–33, 1962.
- [14] L. Cooper, "Location-allocation problems," *Oper. Res.*, vol. 11, no. 3, pp. 331–343, 1963.
- [15] L. Cooper, "Heuristic methods for location-allocation problems," *SIAM Rev.*, vol. 6, no. 1, pp. 37–53, 1964.
- [16] R. Brown, "Calendar queues: a fast  $O(1)$  priority queue implementation for the simulation event set problem," *Commun. ACM*, vol. 31, no. 10, pp. 1220–1227, Oct. 1988.
- [17] C. H. Papadimitriou and K. Steiglitz, *Combinatorial Optimiza-*

*tion: Algorithms and Complexity*, Prentice-Hall, 1982.

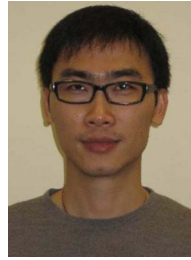

mobile wireless networking.

**Ji Li** (S'04) received the B.Eng. degree in electrical engineering from South China University of Technology, Guangzhou, P. R. China, and the Ph.D. degree recently from ARC Special Research Center for Ultra-Broadband Information Networks, Department of Electrical Engineering, University of Melbourne, Australia. His research interests include network dimensioning and planning, teletraffic theory, stochastic processes, wireless sensor networks, and mo-



**Gangxiang Shen** (S'98-M'99) is a Lead Engineer with Ciena US. Before he joined Ciena, he was an Australian Postdoctoral Fellow (APD) and ARC Research Fellow with ARC Special Research Center for Ultra-Broadband Information Networks, Department of Electrical Engineering, University of Melbourne, Australia. He received his Ph.D. from the Department of Electrical and Computer Engineering, University of Alberta, Canada, in January 2006. He received his M.Sc. from Nanyang Technological University in Singapore and his B.Eng. from Zhejiang University in P. R. China. His research interests are in network survivability, optical networks, and wireless networks. He has authored and co-authored more than 40 peer-reviewed technical papers. He is also a recipient of the Izaak Walton Killam Memorial Award of University of Alberta, the Canadian NSERC Industrial R&D Fellowship, etc. His personal URL is <http://www.gangxiang-shen.com/>.